

# A importância da acessibilidade no [re]desenho dos territórios

**Encontros SPERAE \_ Estruturas Residenciais para Pessoas Idosas (ERPI)**

21-09-2017 | Cineteatro Caracas, O. Azeméis

**Paula Teles**

mobilidade e planeamento do território

# 01 | Cidade \_ mosaico de hipermobilidades



## A cidade, mosaico de hipermobilidades

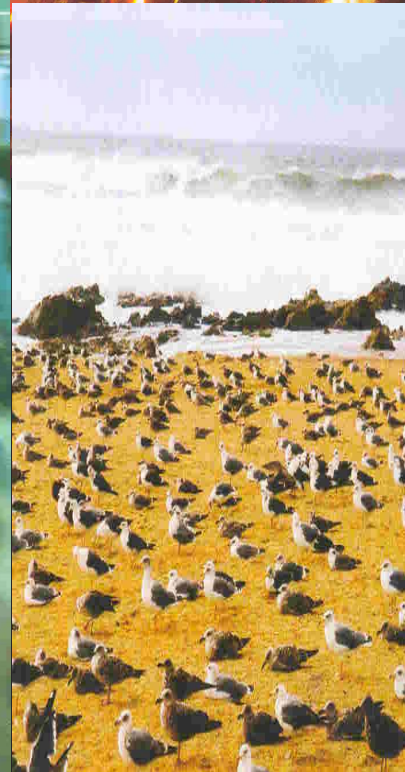
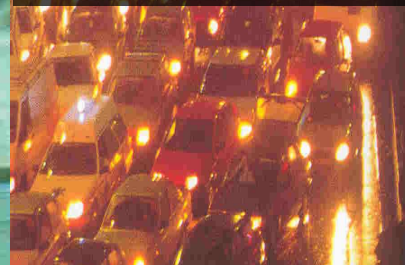
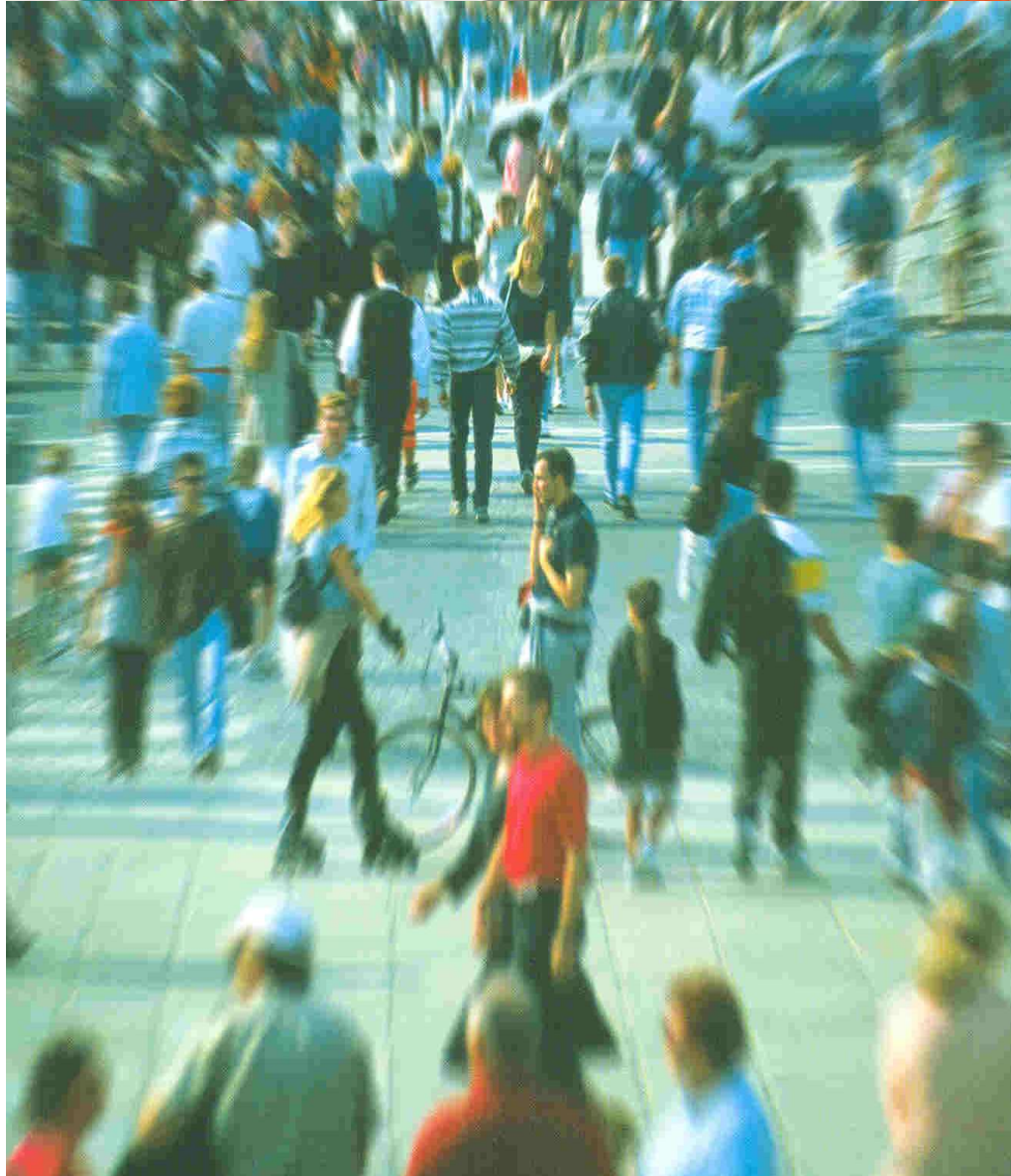

An aerial night photograph of a city street. The street is illuminated by warm yellow streetlights, and the scene is dominated by rows of palm trees. The road surface is marked with blue and white lines, and there are some yellow numbers (59 and 60) visible on the pavement. A few cars are visible on the road, and a white van is parked on the side. The overall atmosphere is urban and modern.

# Falar de MOBILIDADE...

- É compreender as novas realidades urbanas e sociais em emergência.
- É incluir nessa representação de fluxos, as formas e modos de ir de um lugar a outro.
- É saber quem os faz, quais os motivos e quando são feitos.
- É perceber os novos ritmos de vida que hoje desenham os Territórios (sociais) da Mobilidade.

Fonte: (Teles, 2005) Os Territórios (Sociais) da Mobilidade um desafio para a Área Metropolitana do Porto

An aerial photograph of a city with a dense grid of streets, viewed from a high angle. The streets are straight and parallel, creating a repetitive pattern across the landscape. The colors are muted, with various shades of blue, grey, and brown. The text is overlaid on the top half of the image.

“A CIDADE

---

É O LUGAR DOS  
TRAJETOS...”

*Paul Virilio*

---

An aerial photograph of a densely packed urban area, likely San Francisco, showing a mix of high-rise skyscrapers and mid-rise apartment buildings. The text is overlaid on the image.

“A CIDADE FEITA DE  
**PEDAÇOS**”

*Alfonso Brezmes*





# Espaço público inacessível

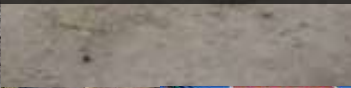





# Edifícios inacessíveis

## **02 | 'Novas' realidades sociais**



---

**Aumento da Esperança Média de Vida**

---





**eDoso**



  
**iDoso**



100



Trabalhar até mais tarde...



RITZ		YOGURTE GELADO LIGHT		FROZEN YOGURT LIGHT		GEFRORENEN JOGHURT LICHT	
				TOPPINGS			
2,70€	3,70€	2,70€	3,70€	0,40€	0,40€	0,40€	0,40€

**Novas realidades  
sociais**

**O direito à mobilidade**



**Novo conceito de  
acessibilidade**

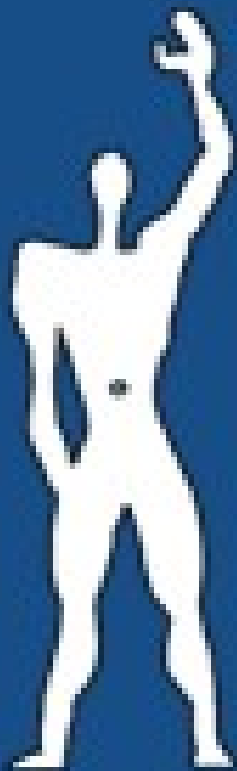

**Novos  
desenhos**

**Direito à mobilidade**



**03 | O que nos dizem os números?**

# 03. O que nos dizem os números?

## A demografia e a acessibilidade

- População portuguesa aumentou essencialmente devido à imigração;
- Nascimentos contribuíram pouco para este aumento;
- População idosa **aumentou**.

População residente em 2001 e 2011

Portugal	2001		2011	
	Nº	%	Nº	%
População residente	10 356 117	100	10 562 178	100
Homens	5 000 141	48,3	5 046 600	47,8
Mulheres	5 355 976	51,7	5 515 578	52,2

Estrutura etária da população, 2001 e 2011

Portugal	2001		2011	
	Nº	%	Nº	%
Estrutura Etária				
0-14 anos	1 656 602	16,0	1 572 329	14,9
15-24 anos	1 479 587	14,3	1 147 315	10,9
25-64 anos	5 526 435	53,4	5 832 470	55,2
65 ou mais anos	1 693 493	16,4	2 010 064	19,0

Estrutura etária da população residente, por sexo, 2001 e 2011

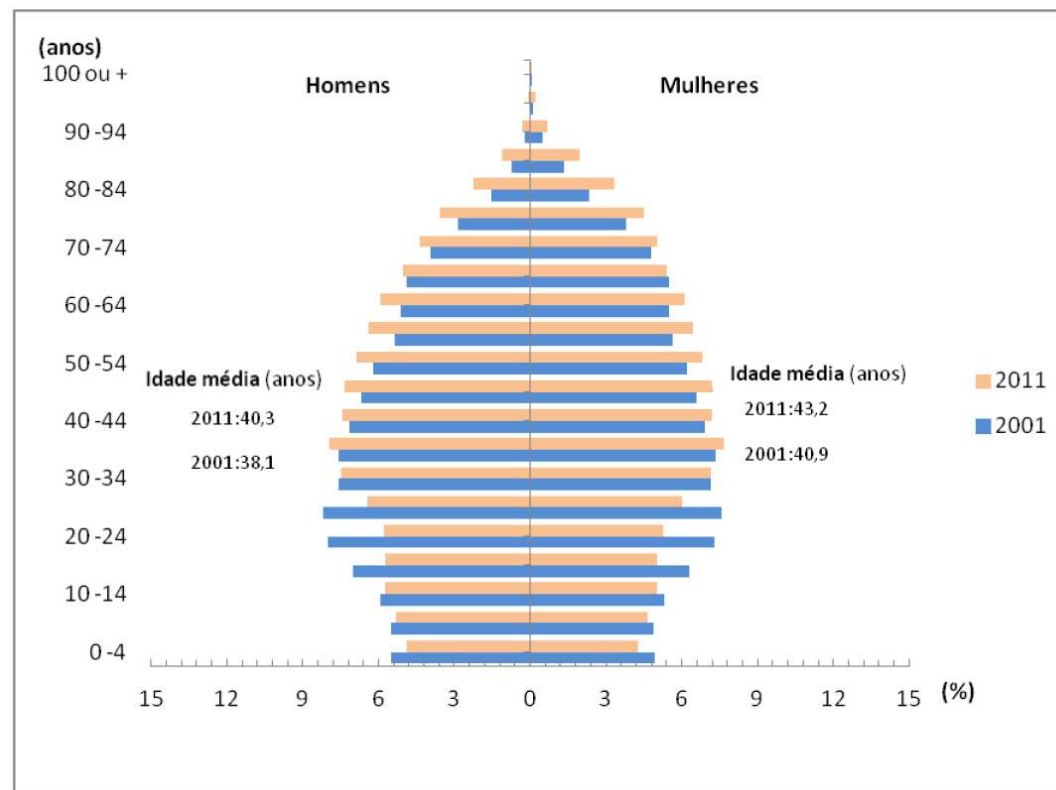

# 03. O que nos dizem os números?

## A demografia e a acessibilidade

- 1,8 milhões de pessoas tem **muita dificuldade ou não consegue realizar tarefas básicas diárias** (ouvir, ver, andar, memorizar, compreender, etc.)
- 18% da população com +5 anos tem muita dificuldade ou não consegue realizar pelo menos uma das 6 atividades diárias;
- **Na população com +65 anos, este indicador ultrapassava 50%;**
- Nas pessoas com +5 anos, com pelo menos uma dificuldade, ANDAR (com 25% das respostas), era a principal limitação na realização das tarefas diárias;
- Cerca de **23%** das respostas identificam a **dificuldade em VER**, mesmo usando óculos ou lentes de contacto, sendo esta a segunda dificuldade mais representada.

# **04 | A legislação portuguesa e boas práticas**

# 04. A legislação portuguesa e boas práticas

## Guia de Acessibilidade e Mobilidade Para Todos

Manual técnico com  
legislação desenhada  
DL 163/2006

Lançado em 2007



# 04. A legislação portuguesa e boas práticas

## Mapas de acessibilidade



# 04. A legislação portuguesa e boas práticas

## Certificado de Acessibilidade ICVM

O Certificado de Acessibilidade - ICVM permite identificar os locais onde o acesso universal às atividades económicas, sociais e culturais está garantido, reconhecendo o seu nível de acessibilidade.





# **05 | A importância da aplicação do design universal a produtos e ambientes**

# 05. A importância da aplicação do design universal a produtos e ambientes

## Design universal

**A concepção de produtos e ambientes utilizáveis no maior grau possível por pessoas de todas as capacidades.**

Os destinatários de soluções mais inclusivas, **são todos os cidadãos** e não apenas aqueles que apresentam maiores dificuldades de interação com o meio.

Não se trata apenas de uma política assente na solidariedade pelos direitos dos outros, mas de assegurar os nossos próprios direitos para o futuro, quer em **situação excepcional de acidente, quer por motivos inevitáveis de envelhecimento.**

# 05. A importância da aplicação do design universal a produtos e ambientes

## Os 7 princípios do design universal

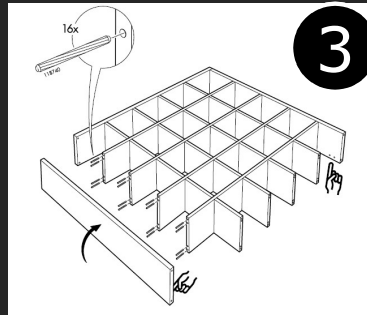

1 . Uso equitativo

2 . Flexibilidade no uso

3 . Simples e intuitivo

4 . Informação perceptível

5 . Tolerância ao erro

6 . Pequeno esforço físico

7 . Tamanho e espaço para a aproximação e uso

# **06 | Ideias e projetos \_ acessibilidade com design**

# Espaço exterior público

Percursos pedonais  
acessíveis / continuidades  
urbanas



# Espaço exterior público

Percursos amplos e livre de obstáculos



# Espaço exterior público

Estacionamento para pessoas com mobilidade reduzida



# Espaço público interior









# Espaço público interior

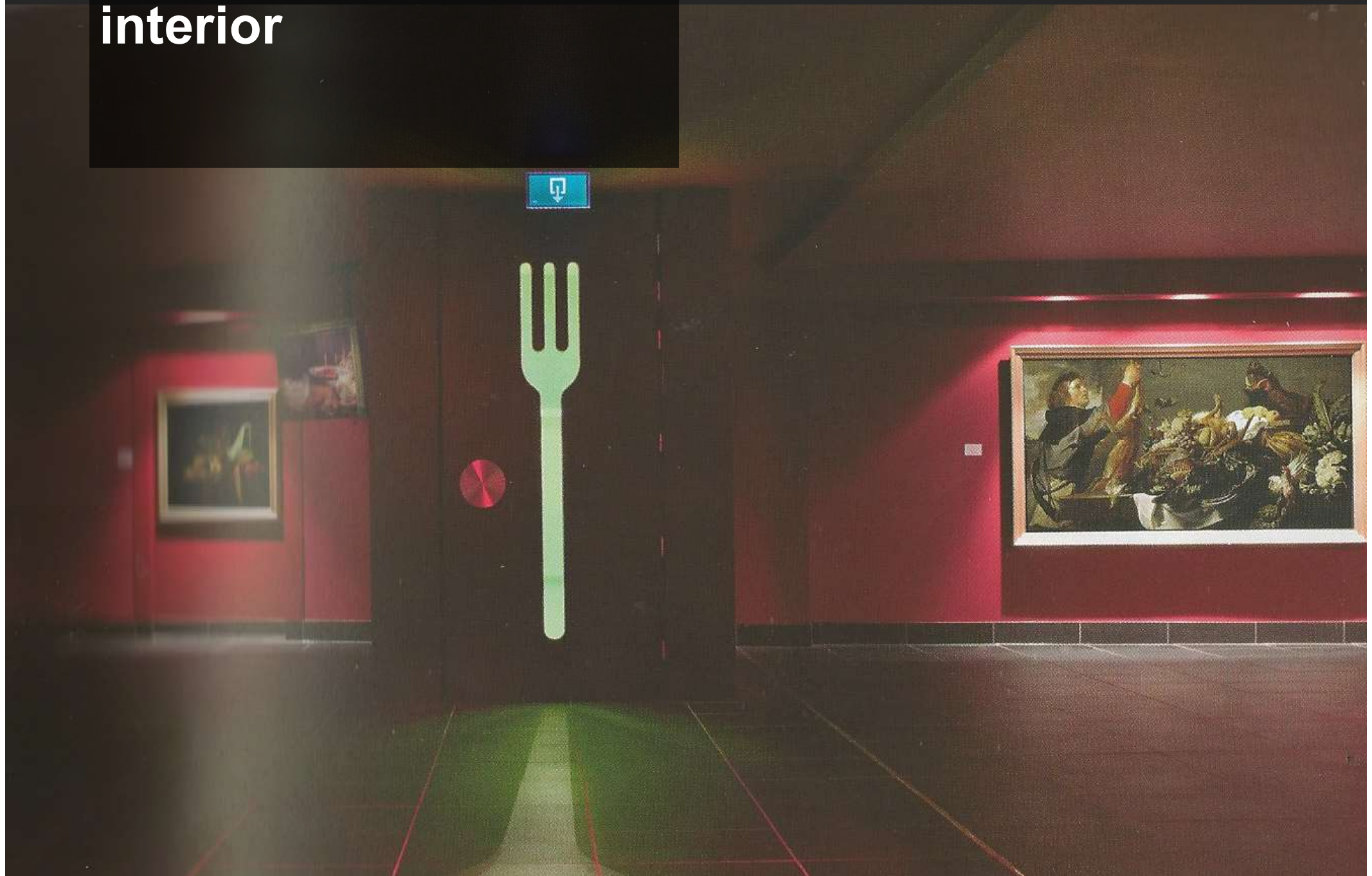

**Espaço exterior  
privado**

**Comodidades lúdicas**



# Acesso ao edifício

Elementos facilitadores:  
rampa e porta automática

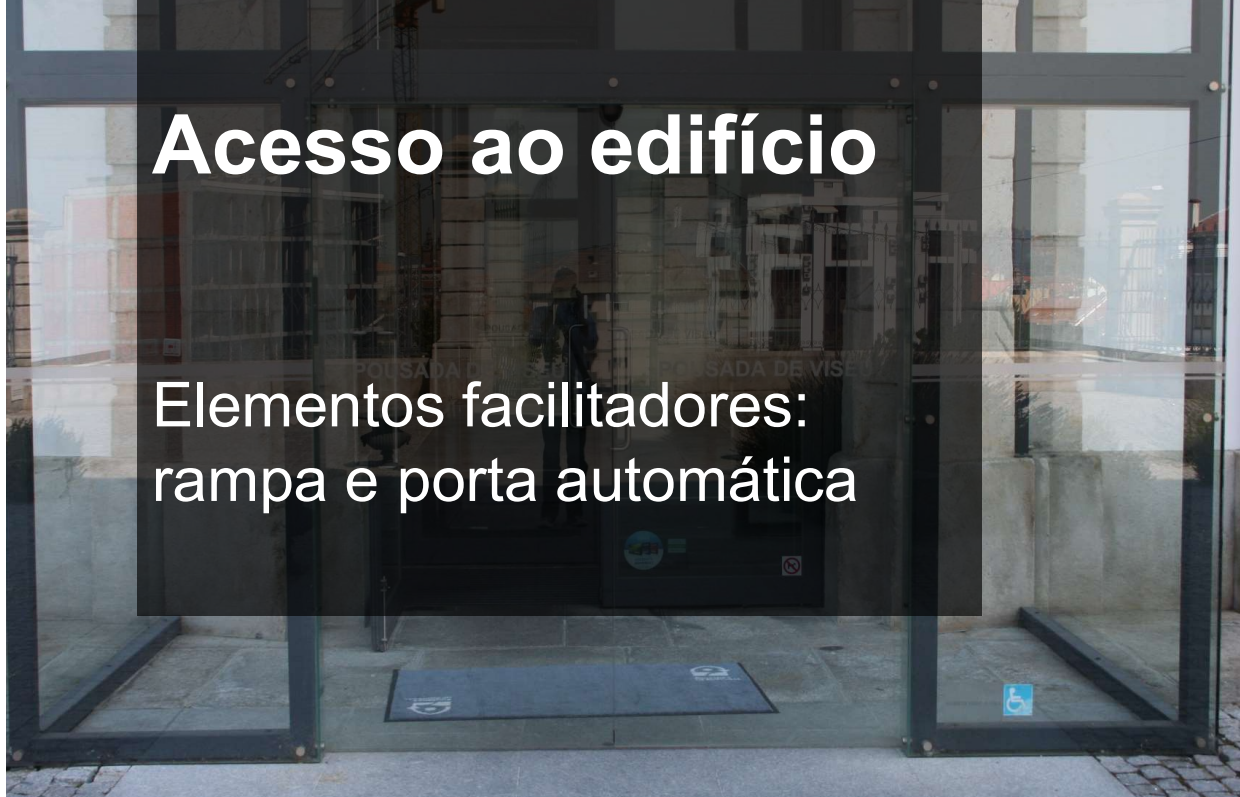

# Distribuição interior

Espaços amplos que facilitam a circulação a pessoas



# Distribuição interior

Acessos verticais



# Distribuição interior

Acessos verticais

ORONA

ORONA

1

1

4

2

3

-1

1





# Distribuição interior

Acesso a dependências

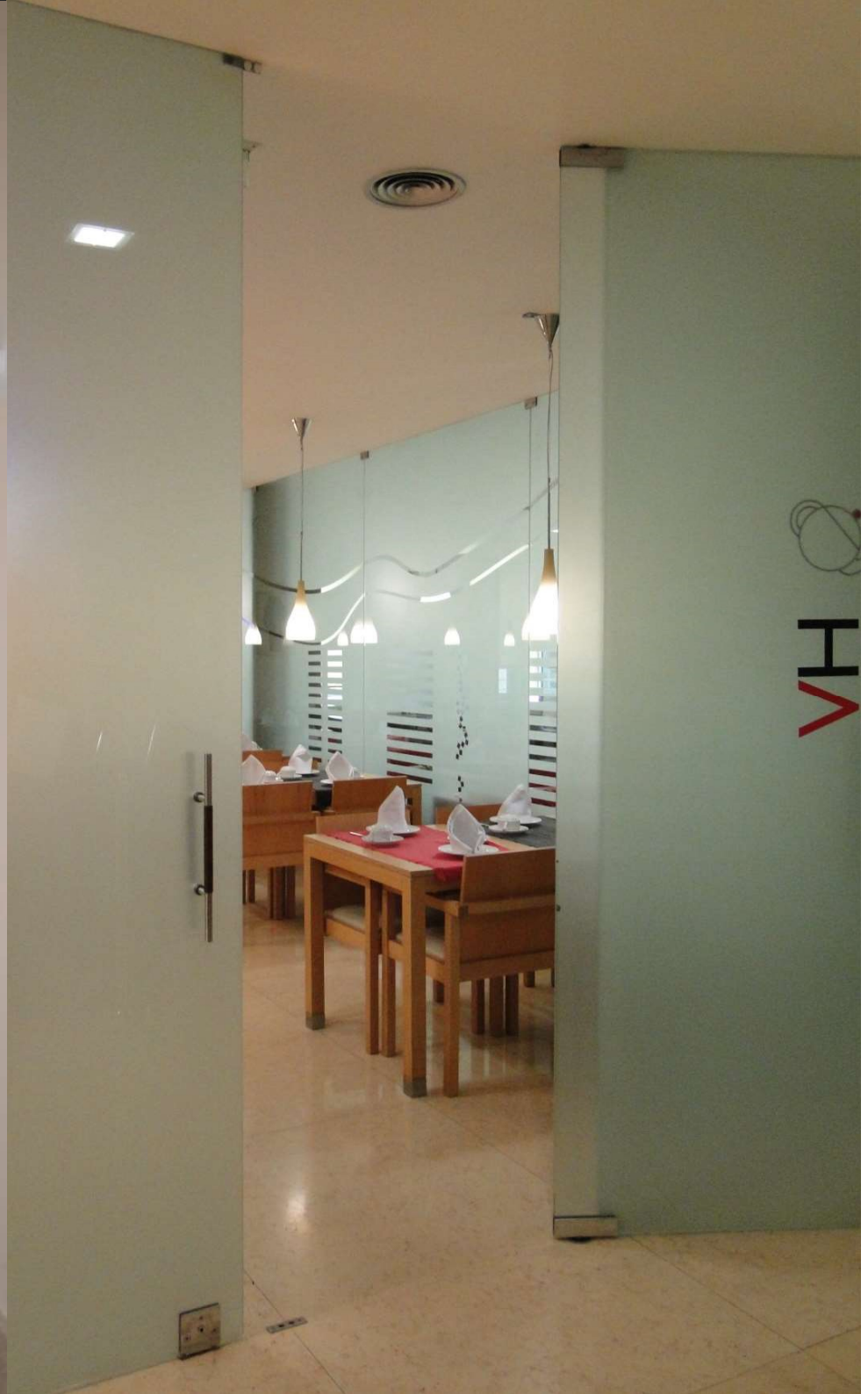

# Distribuição interior

Acesso a dependências

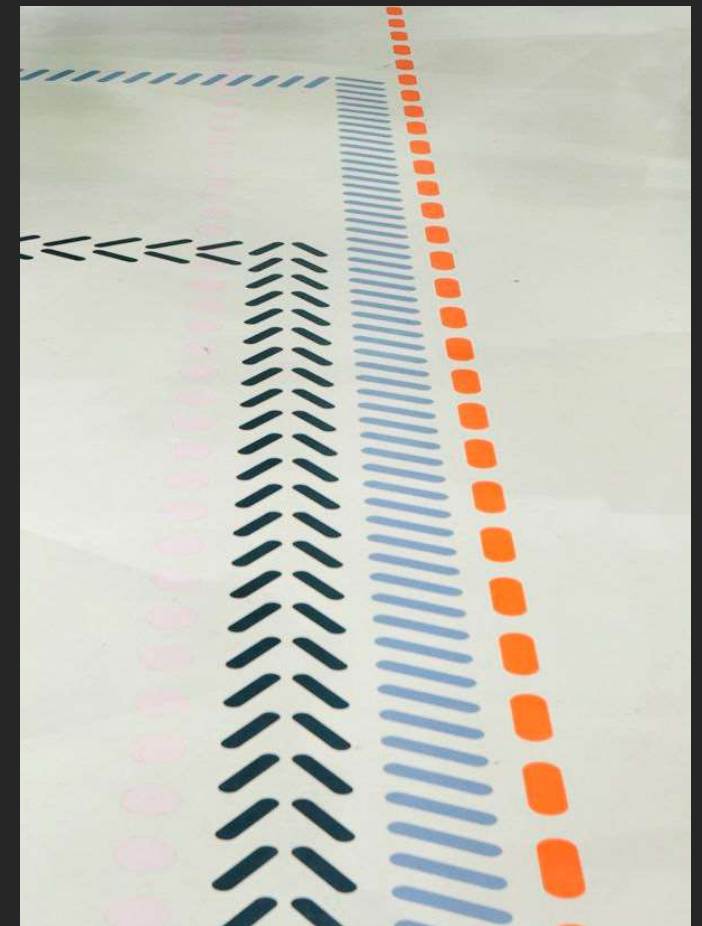

# Dependências



**Espaços acessíveis não necessitam  
de ser enfadonhos e a 'preto e branco'!**



# Dependências









# Dependências







# Dependências



# Dependências



# Dependências





# Sinalética

Design inclusivo





# Espaço Público

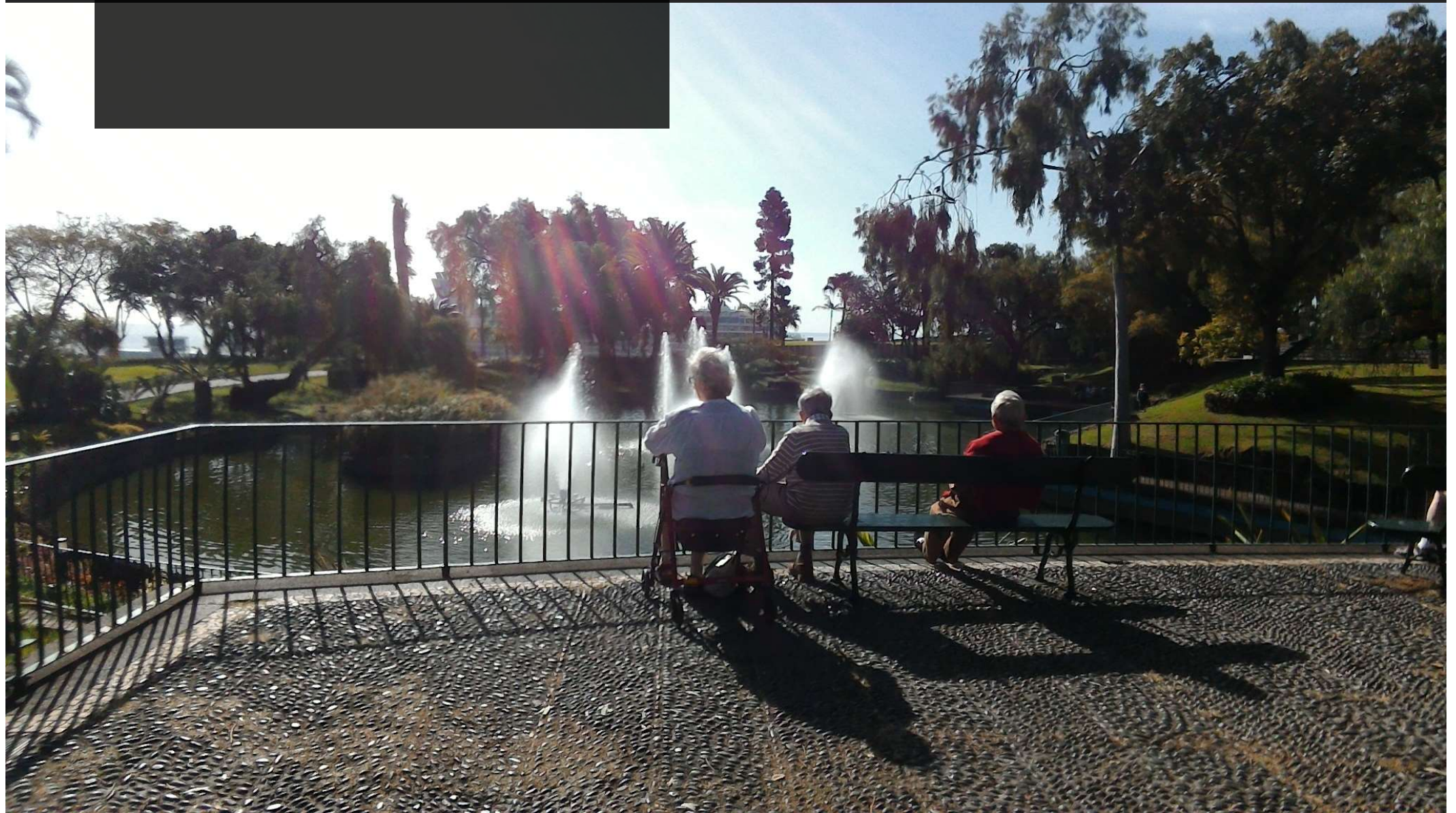







Casa do Povo de  
Santa Cruz de Alvarenga

Lare Creche





**Obrigado pela  
atenção!**

**Paula Teles | paulateles@paulateles.pt**

mobilidade e planeamento do território